



Smart devices > Smart networks > Smart Planning

Technical White Paper

Analysis Techniques for WiMAX Network Design Simulations



Analysis Techniques for WiMAX Network Design Simulations

Jerome Berryhill, Ph.D. EDX Wireless, LLC
Eugene, Oregon USA
October 2008

Overview

The factors that determine the behaviors of a wireless network are numerous and complicated. In addition to static factors such as the location and operating characteristics of base station equipment, terrain, clutter and building distribution, the system is also sensitive to time-dependent factors including the locations and behavior of large numbers of both mobile and fixed remote users. There are various techniques one might adopt to predict the behavior of these users. This paper looks at the techniques used in traditional network planning and then proposes an alternate method.

One of the techniques that can be used is with a fully deterministic model, but the effort required to implement this type of model so that every single user is analyzed in every single situation is not justified by the very limited reliance which can be placed upon the results. Therefore the problem of simulating the properties of such a system appears to be intractable.

When confronted with a seemingly intractable problem, it is natural to “try a few cases”, to “get a feel for” the problem. When that “feel” only confirms the original impression of intractability, one is tempted to simply expand the number of cases until it no longer feels like “a few”, and then characterize those cases by statistical means. Modern computers using randomizing functions can easily generate very large sets of cases and also perform the statistical computations. This natural progression leads one to develop what is commonly termed a “Monte Carlo” simulation. In formal terms, Monte Carlo is a means of estimating some property of a probability distribution. One begins with one or more state variables defining a point in the space of all possible outcomes, known as the sample space. Each outcome is assumed to be equally likely. One then requires an algorithm for evaluating the desired property at that point. Monte Carlo is usually applied when the sample space is so large that it is not practical to apply the algorithm to all possible states.

From the software developer’s perspective this approach is very attractive. A problem analysis which appeared to be a dead end now becomes the basis for a solution. The simulation may be made as simple or as complex as resources permit. By averaging over a large number of cases, the method ensures that the result will fall within the range of possibility. The number of cases can always be adjusted to make the calculation terminate in an acceptable amount of time. In short, the Monte Carlo method always “works”. Once the developer has decided that he will take a Monte Carlo approach to a problem, he can be sure that he will be successful in producing a set of results. That fact goes a long way to explain the popularity of this method.

On the other hand, from the user’s standpoint the situation is not so clear. The widespread use of Monte Carlo methods has led to the perception that they are “accepted” and must therefore always be valid. This is far from being the case. While there are problems which can be dealt with using Monte Carlo, care is required to see whether it is justified in any given situation. The Monte Carlo method consists in choosing a random subset of all possible states and calculating the statistical properties over that subset, in the hope that the results will approximate those one would get for the complete set. Whether this hope is justified depends upon a number of factors.



Monte Carlo is best suited to smooth distributions, which vary slowly with the state variables. A smooth variation implies that every point in the problem set is a good representative for nearby points so that the result does not depend sensitively upon which of them is chosen. When the distribution is chaotic (large changes in outcome for small changes in the state variables) Monte Carlo may produce substantially different results from one run to the next. In spite of this it is often applied to situations which are chaotic, with very large changes in outcome for small changes in initial state.

Often, turning to Monte Carlo is the analytical equivalent of throwing up one’s hands. The validity of the result is literally anybody’s guess: unknown, and unknowable. It may be that nothing further can be said about the problem and this approach at least dispenses with it. But it is also possible that further analysis will reveal other approaches to the problem. The appearance of a seemingly intractable problem may simply indicate that one is asking the wrong question.

Case Study: WiMAX Uplink Interference

A major concern for distributed wireless networks is uplink interference. It will generally be the case that some Subscriber Stations (SS's) have high signal strength at multiple Base Stations (BS's), while others have low strength at all BS's. For example, the signal from an SS (SS-A) on a hilltop may be strong at many BS's, while another (SS-B) down in a valley may not have a very strong signal at any BS, including the BS it is assigned to. In that case, SS-A will "drown out" SS-B.

In contrast to other mobile wireless systems, where a Subscriber Station (SS) uses the same frequencies for uplink transmission during the full duration of a connection, WiMAX Uplink interference is an inherently stochastic (probabilistic) phenomenon. The WiMAX frame can be illustrated by a rectangle, with frequency along the vertical axis and time as the horizontal axis. A single point in this frame is a “slot”, the minimal unit of frame allocation. A portion of this rectangle is reserved for uplink transmissions (see Figure 1). The WiMAX system scheduler algorithm in the Base Station (BS) assigns a portion of this uplink frame to each SS, and communicates this assignment in the UL-MAP portion of the frame.

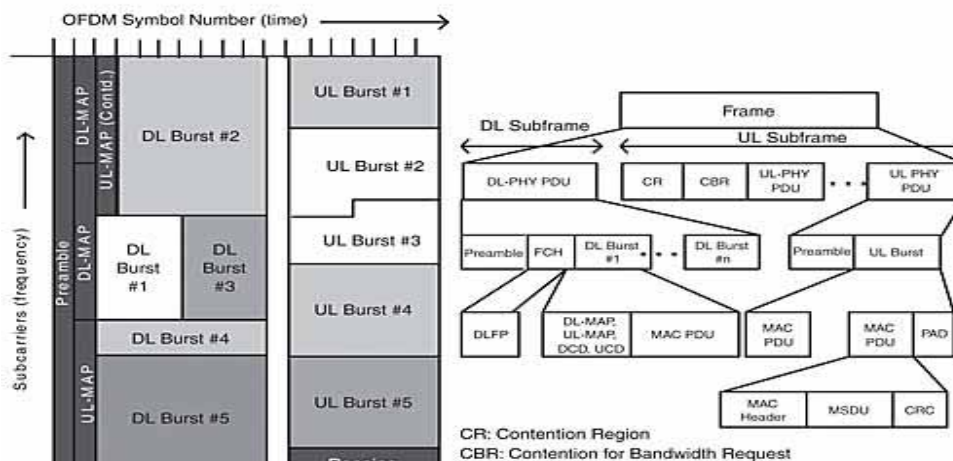

Figure 1 - WiMAX Frame Structure1

Analysis Techniques for WiMAX Network Design Simulations



Uplink interference can only occur if two SS's happen to be using the same portion of the frame. It might be supposed then that the problem of uplink interference could be modeled using a Monte Carlo simulation in which a scheduler algorithm laid out consecutive uplink frames for a set of BS's using randomly generated traffic. By combining the frame assignments with power levels derived from a propagation model, it is possible to determine the level and duration of signal and interference arriving at each BS.

During actual network operation, the scheduler considers a large set of variables while making frame assignments and the set of possible cases is astronomical. Even a very fast computer could not calculate the outcome for each case in a reasonable time. It might be supposed that the problem of uplink interference could then be approached using a Monte Carlo simulation in which a scheduler algorithm laid out consecutive uplink frames for a set of BS's using randomly generated traffic. By combining the frame assignments with power levels derived from a propagation model it should then be possible to determine the level and duration of signal and interference arriving at each BS. Unfortunately, the details of the WiMAX equipment scheduler algorithm will generally be proprietary so we lack sufficient knowledge to build a valid simulation. Additionally, it can be anticipated that the frame allocation will be very sensitive to changes in traffic, to the point that it may well change every frame. This indicates that the target distribution is chaotic; i.e. a small change in the inputs, such as a new connection, or a retransmit request, can cause changes in the frame mapping which may completely alter the interference. As discussed above, the validity of a Monte Carlo simulation under these conditions is dubious.

However, when viewed from another perspective the chaotic nature of the process allows it to be directly treated as a stochastic process. Using this approach we need not concern ourselves with the factors determining the actual layout of any given frame. Instead, we can simply consider the probability that any given SS will interfere with any other (at the BS) based upon their propagation characteristics and the duration of their transmissions. Given the stochastic nature of the scheduling process, any portion of the uplink frame is equally likely to be assigned to any SS. The probability that one of SS-B's slots will be stepped on by part of SS-A's transmission is simply the frame fraction of SS-A – the number of slots in SS-A's transmission divided by the number of slots in the frame. For example, if each SS was assigned to one tenth of the frame (an unlikely extreme allocation of resources), one would expect one tenth of the SS-B data block to be "stepped on" by SS-A, resulting in an Interference Frame Fraction (IFF) of 1%.

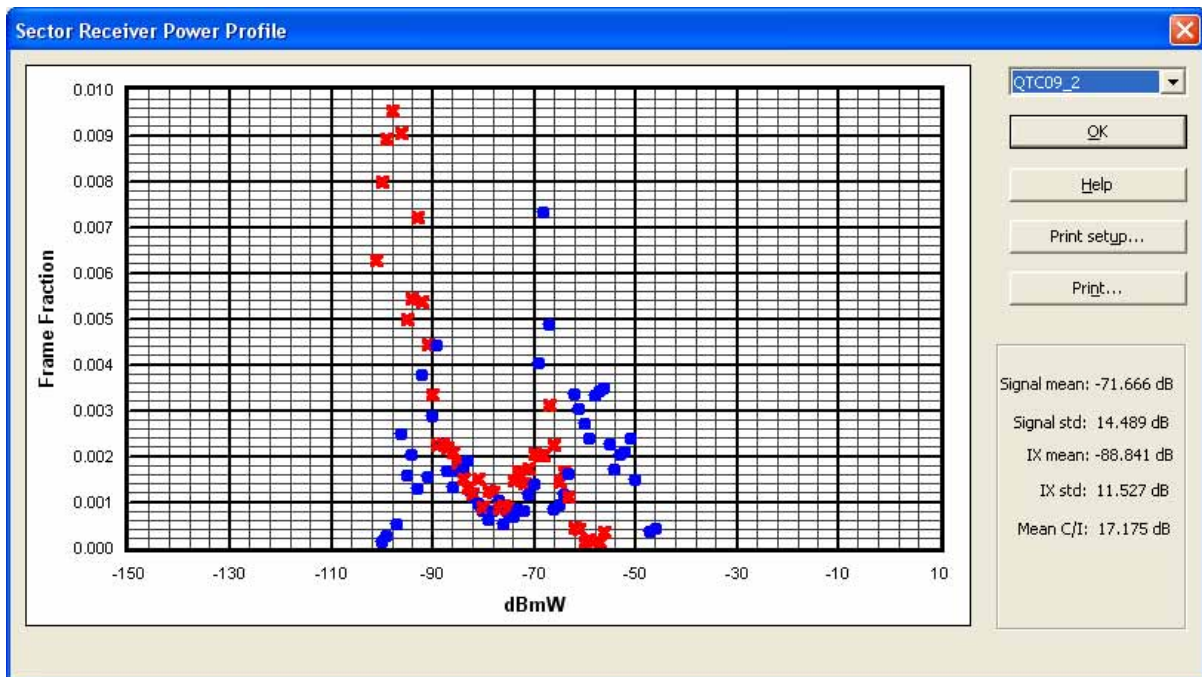

Figure 2 Frame Fraction Profile

The EDX® SignalPro® Uplink Frame Stochastics study models this process by allowing the user to assign a traffic volume to points (representing SS's) within the service area grid.

A modulation type is assigned to the point based upon the calculated signal strength at the BS and the number of slots required to transmit the uplink data is dependent upon this modulation type. This SS transmission will be seen as signal at the assigned BS, and interference at all other BS's. One can therefore calculate a Signal Power Profile and an Interference Power Profile for each BS, showing the frame fraction transmitted at each BS received power level. These profiles can be displayed for each sector by EDX SignalPro as shown in Figure 2 (blue = Signal SS, red = Interfering SS). Clearly, it is desirable for the received signal profile's maximum to be clustered around a higher power than the interference profile. Alternately, significant overlap of these profiles indicates that there will be significant interference problems at that sector.

This area study produces a geographic display (Figure 3) showing the "% Clear" at each point in the study area. The program calculates the power that the SS will deliver to its assigned BS from the point, and decreases it by the $C/(I+N)$ required for the assigned modulation. It then calculates the total frame fraction of interference for that BS which is above this threshold level to give the portion of the data transmitted from that point which will not encounter interference problems. This is displayed as a percentage on the map.

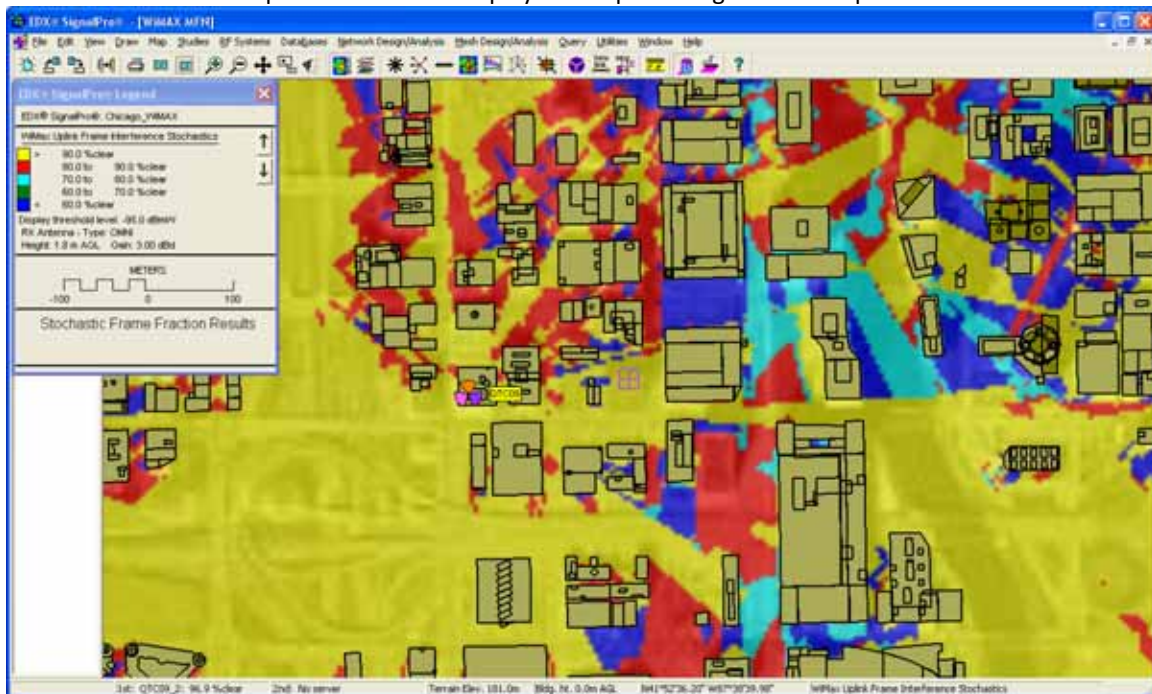

Figure 3 Frame Stochastics Area Study

This study also produces a text report showing the traffic estimates and IFF for each BS. The estimated traffic and service types at each SS location are considered with the slots for UGS connections being fully satisfied first before assigning the slots for the various best effort types of services. It also assumes that some additional slots will likely be required by UGS to repeat the data blocks which encountered high-power SS interference.

From an engineering standpoint, the result of interference is that data may need to be retransmitted, reducing total system capacity. While the precise nature of the interference in any given frame will depend upon the details of the scheduling algorithm, over even a fairly short time the data lost to interference will be well approximated by



the total IFF for the BS. We are therefore able to eliminate the need for the information we lack (the details of the scheduler algorithm) while developing a measure of system performance (Total BS IFF) which depends upon the things that can be well modeled such as system power and the propagation environment.

Conclusions

Our initial analysis of the WiMAX uplink interference problem indicates a dependence upon a process (scheduling) which cannot be modeled accurately. Given this, we might therefore consider a Monte Carlo approach. However, further analysis shows that the details of this dependence are not relevant to the engineering question. We can treat the scheduler operation as a stochastic process and concentrate instead on the elements of the problem which are well defined and easily calculated using traditional RF simulation techniques. For these reasons EDX's straightforward calculation approach, beginning with a fixed traffic definition, and evaluating the frame stochastics directly results in a fast and efficient algorithm that produces a reliable, consistent, and practical result.

Bibliography

[1] http://www.wimax.com/commentary/wimax_weekly/2-3-5-slot-and-frame-structure

[2] Eklund, Marks, Ponnuswamy, Stanwood, van Waes, WirelessMAN® Inside the IEEE 802.16e™ Standard for Wireless Metropolitan Networks, IEEE Press, 2006

[3] J. Andrews, A. Ghosh, R. Muhamed, Fundamentals of WiMAX: Understanding Broadband Wireless Networking, Prentice Hall, 2003